



RHINO-24PLR

Hydraulic Flange Alignment Tool

The RHINO-24PLR is a Hydraulic flange alignment tool designed for large flanges on the inside of wind turbine towers during their assembly or installation and is used to correct:

- **Bolt-hole misalignment**
(when the tower sections of the turbine towers are not Axially aligned).
- **De-ovalizing**
(when the flanges are not truly concentric to the axis of the tower due to deformation or manufacturing tolerances).

The RHINO-24PLR can produce a maximum reaction alignment force of 238kN when the maximum hydraulic pressure of 5,000psi (350 Bar) is generated in the tool.

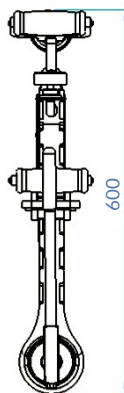
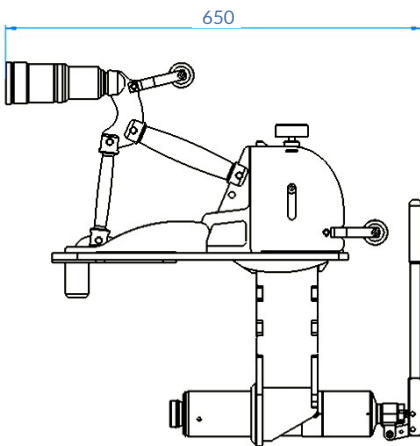
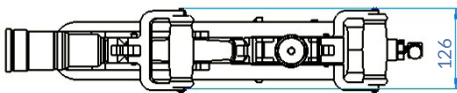

- Tool weight 25Kg
- No external anchor points or rigging required.
- Can be used to prevent misalignment during flange joint maintenance or wind turbine tower assembly or installation.
- 100% Load/Pressure tested and certified.
- Adjustable Wing and Drop Leg to increase application range.
- Prevents gasket pinching during flange joint assembly.
- High durability High Quality low Maintenance design.
- Supplied with internal PRV for safety.
- Robust Transit Case for easy transportation and storage.
- Twin Lifting Handles with Comfort Grips for ease of handling.



Engineered Energy Equipment

Product Sales | Product Rental | Bespoke Solutions

RHINO-24PLR

Hydraulic Flange Alignment Tool



Force Diagram

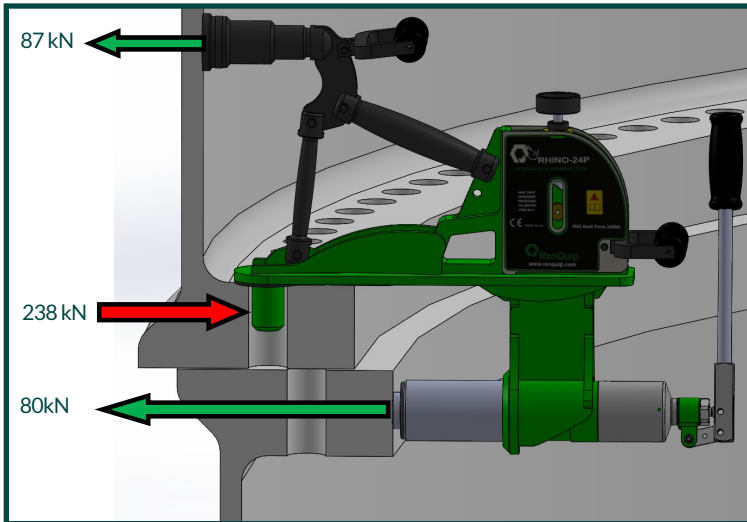

Application Dimensions

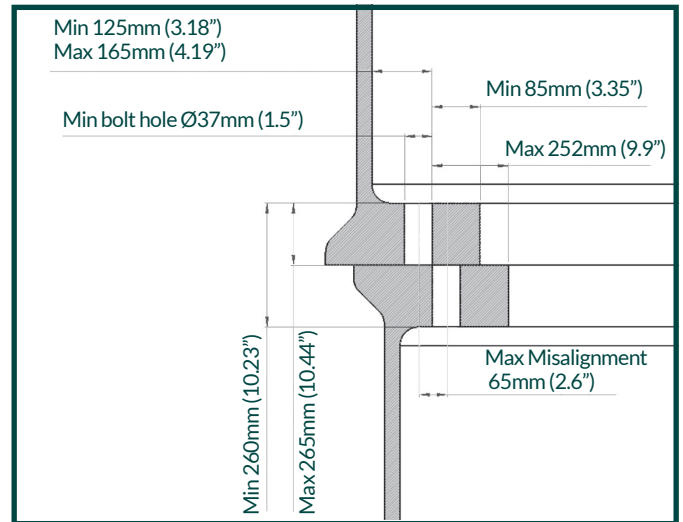

Kit Content:

- 1 x RHINO-24PLR Tool
- 1 x Instruction Manual
- 1 x Safety Lanyard
- 1 x Storage and Transport Case

Kit weight : 40Kg

Kit Dims.: 820mm x 680mm x 220mm

Tool Weight: 25Kg

Tool Dims.: 650mm x 600mm x 126mm

Product ordering code: RHINO-24PLR



Engineered Energy Equipment

Product Sales | Product Rental | Bespoke Solutions

www.renquip.com

Unit 1 Dunnottar House, Howe Moss Drive, Dyce, Aberdeen, AB21 0FN
+44(0) 1224001861 | info@renquip.com

