



RenQuip



OPERATION MANUAL

Viper-28K

Viper-28M

Viper-28H

Hydraulic Flange
Spreading Wedge

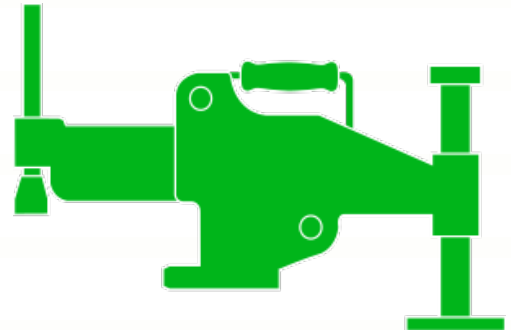

Engineered Energy Equipment

www.renquip.com



Contents

1. Introduction	Page 2
2. Safety Information	Page 3
3. Specification	Page 4
4. Operation	Page 6
5. Stepped Block Attachment	Page 11
6. Parts List	Page 12
7. Maintenance	Page 13

1.0 Introduction

The RenQuip Viper range of Flange Spreading Wedges are designed to open flange joints with a minimum access gap of 5mm. The Jaws of the tools open in a parallel motion which maintains a safe, full step contact between the tool and the flange.

The parallel Jaw motion also ensures spreading forces are perpendicular to the flange face.

It is highly recommended that 2 or more Flange Spreading Wedges are used together to maintain a parallel Flange joint gap during spreading.

2.0 Safety Information

User Safety



1. The User must be competent in Operating High Pressure Hydraulic Equipment.
2. The User must read and understand the relevant Instruction Manual for the Equipment.
3. The User must wear the correct Personal Protective Equipment .
4. Do not lift or hold pressurised equipment

Equipment Safety

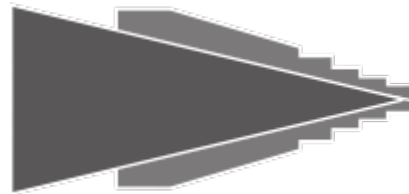

1. Inspect all equipment prior to use for any signs of damage or wear.
2. Ensure all components have a safe working pressure of 10,000psi (700Bar).
3. Do not pressurise equipment over its safe working pressure.
4. Never insert fingers or hands into an open flange joint.
5. Ensure all couplers are fully connected before pressurising the system.
6. Ensure system is fully depressurised before disconnecting couplers.
7. Ensure the working area is free from hazards to the equipment such as sharp objects, heat sources , moving machinery or vehicles.
8. Carry / transport equipment by the handles / cases provided.
9. Store equipment in a cool dry environment .
10. Ensure the correct oil is used in the hydraulic system and maintenance procedures are followed.

3.0 Technical Specification

Application Diagram

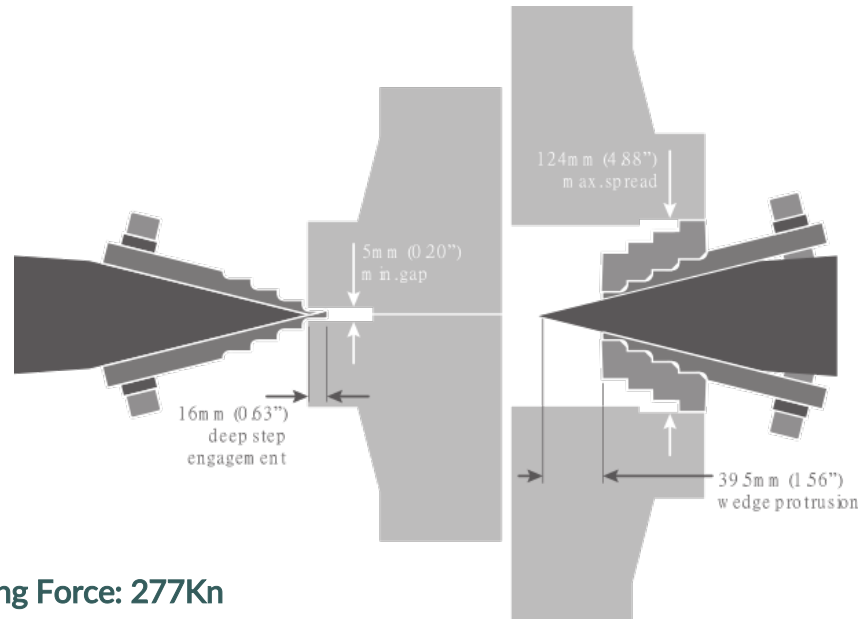

Max Spreading Force: 277Kn

Max working Pressure : 10,000psi / 700 Bar

Model : VIPER-28K

Kit weight:

10.5Kg (23.1lbs)

Kit Dims.:

580mm x 340mm x 180mm
(22.8" x 13.4" x 7.1")

Tool Weight:

5Kg (11.0lbs)

Tool Dims.:

75mm x 133mm x 295mm
(3.0" x 5.2" x 11.6")

Product ordering code:

VIPER-28K

Kit Content:

- 1 x VIPER-28 Hydraulic Flange Spreading Wedge
- 2 x Stepped Blocks
- 1 x Safety Block Set
- 1 x Stepped Safety Block
- 1 x Safety Lanyard
- 1 x Robust moulded carry case
- 1 x Instruction Manual



3.0 Technical Specification

Model : VIPER-28M

Kit weight:

30Kg (66.1lbs)

Kit Dims.:

920mm x 510mm x 210mm
(36.2" x 20.1" x 8.3")

Tool Weight:

5Kg (11.0lbs)

Tool Dims.:

75mm x 133mm x 295mm
(3.0" x 5.2" x 11.6")

Product ordering code:

VIPER-28M

Kit Content:

- 2 x VIPER-28 Hydraulic Flange Spreading Wedges
- 4 x Stepped Blocks
- 2 x Safety Block Set
- 2 x Stepped Safety Block
- 2 x Safety Lanyard
- 1 x PH580T Sealed Hydraulic Hand Pump with Twin Ports
- 2 x 10kH7 Hydraulic Hose c/w couplers
- 1 x Robust moulded carry case



Model : VIPER-28H

Kit weight:

19Kg (41.9lbs)

Kit Dims.:

920mm x 510mm x 210mm
(36.2" x 20.1" x 8.3")

Tool Weight:

5Kg (11.0lbs)

Tool Dims.:

75mm x 133mm x 295mm
(3.0" x 5.2" x 11.6")

Product ordering code:

VIPER-28H

Kit Content:

- 1 x VIPER-28 Hydraulic Flange Spreading Wedge
- 2 x Stepped Blocks
- 1 x Safety Block Set
- 1 x Stepped Safety Block
- 1 x Safety Lanyard
- 1 x PH300S Sealed Hydraulic Hand Pump with Single Port
- 1 x 10kH7 Hydraulic Hose c/w



4.0 Operation of the Viper-28 range

1. Connect the gauge to the pump.

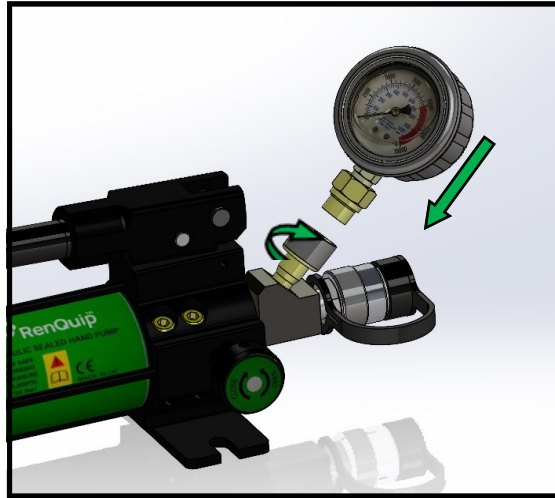

2. Connect the hose to the pump.

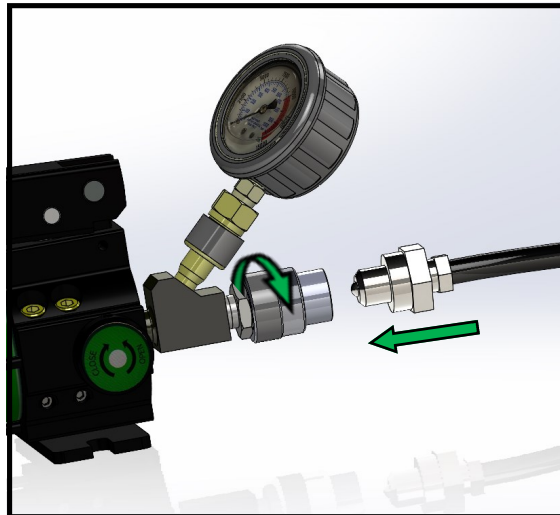

3. Connect the hose to the tool.

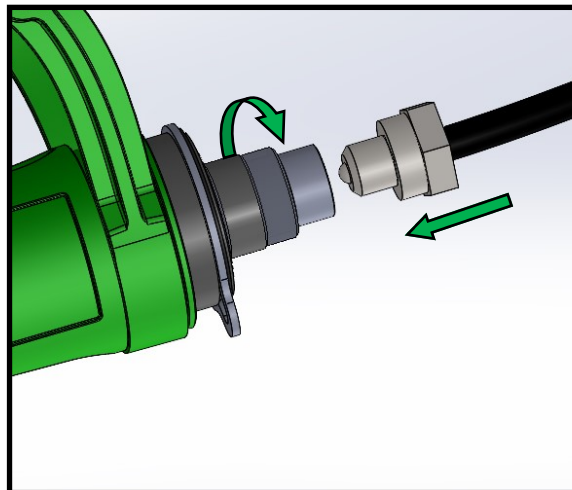

4. Close the pressure release valve.

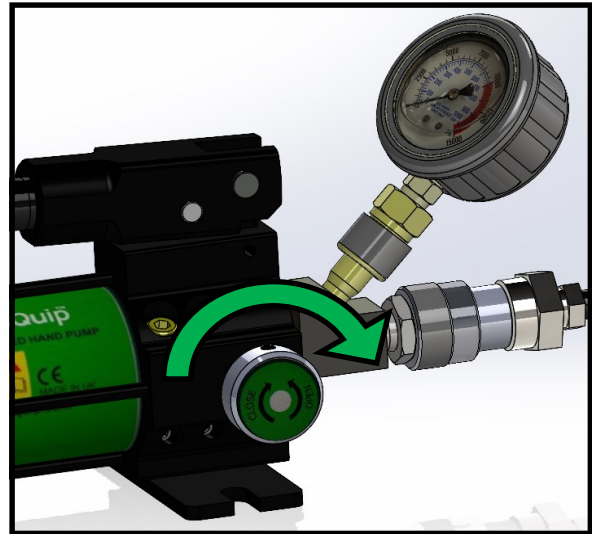

5. Insert the VIPER-28 in to the flange Joint access gap.

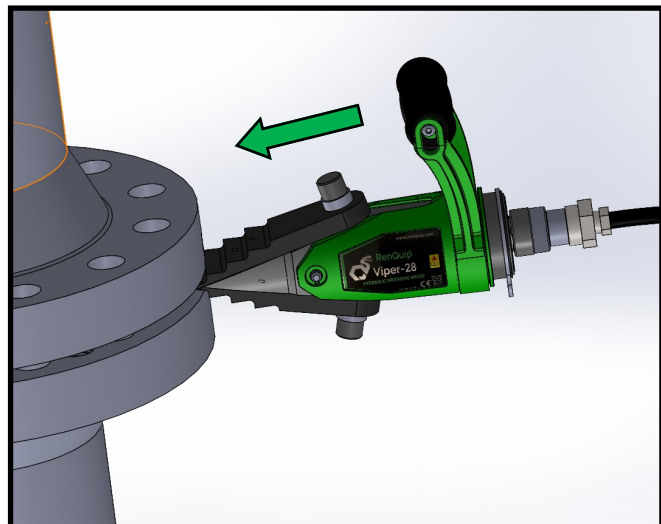

6. Insert the second VIPER-28 to create an even spreading force on the flanges.

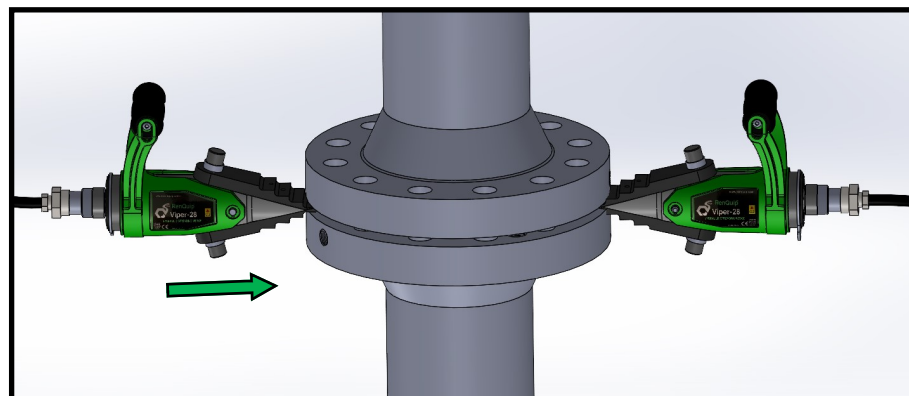



7. Fully Insert tool on each step.

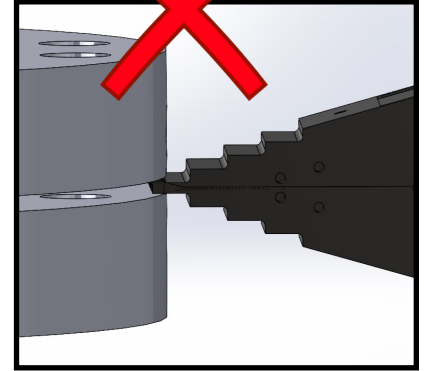
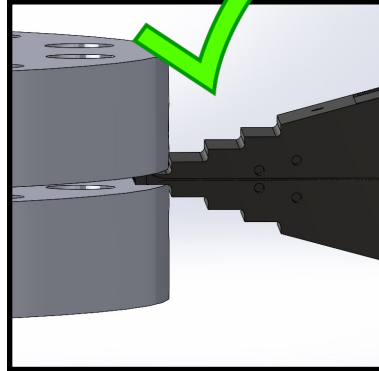

8. Operate the pump handle to pressurise the system.

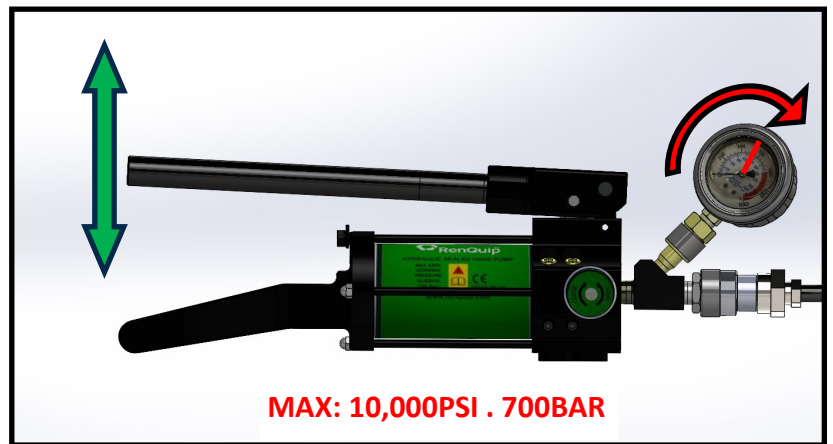

9. When the tool has reached its full stroke or the required flange gap is reached insert the safety block.

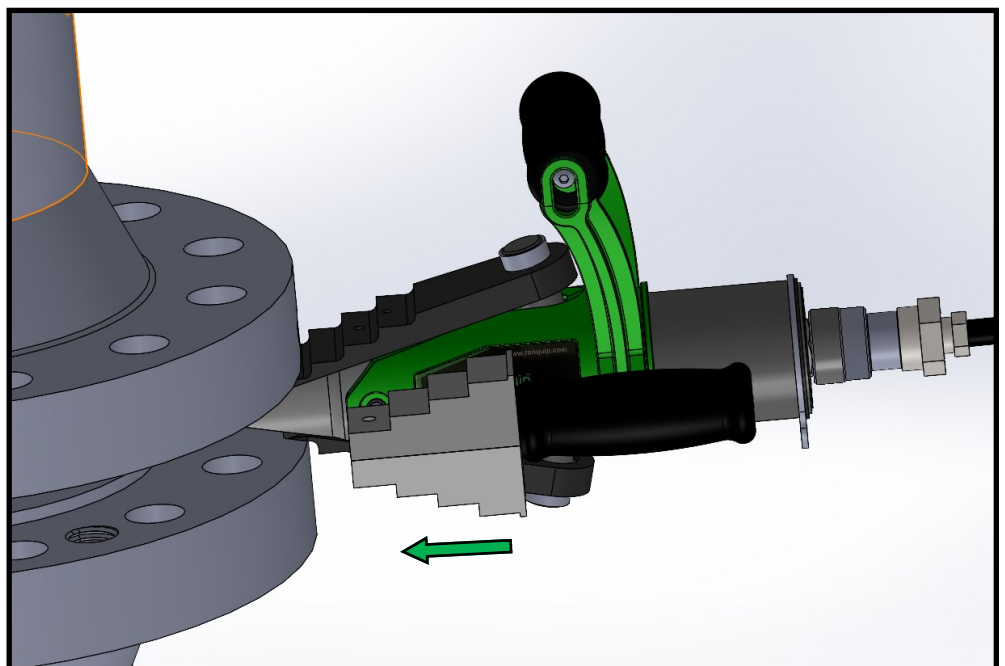

10. Release the pressure.

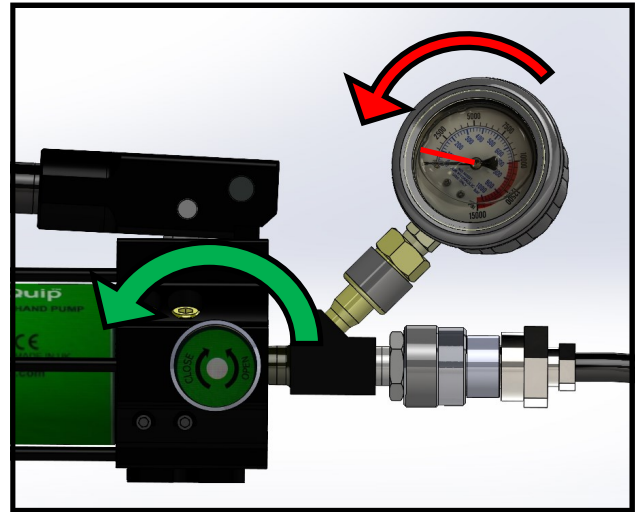

11. If a larger flange gap is required insert the VIPER-28 further into the Flange joint and repeat steps 6 to 9.

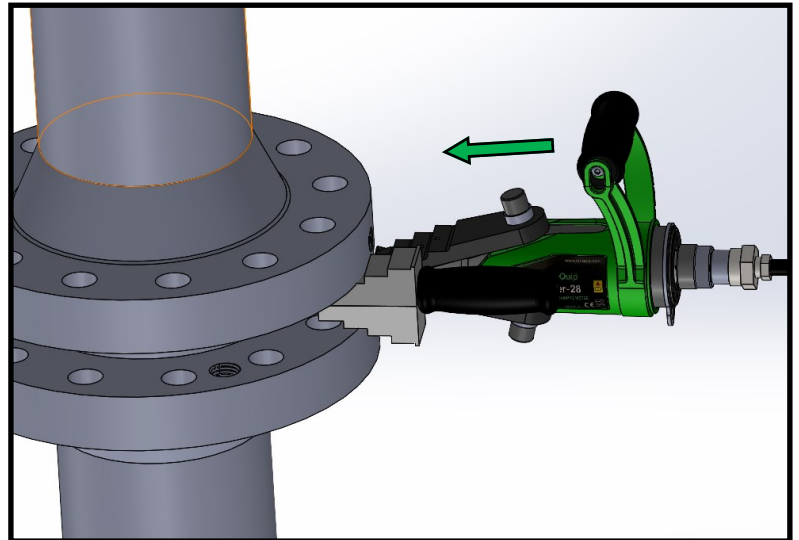

12. When the required Flange gap is achieved, fully insert the safety blocks. The pressure can then be released from the system and the VIPER-28 tools removed before starting any flange works.

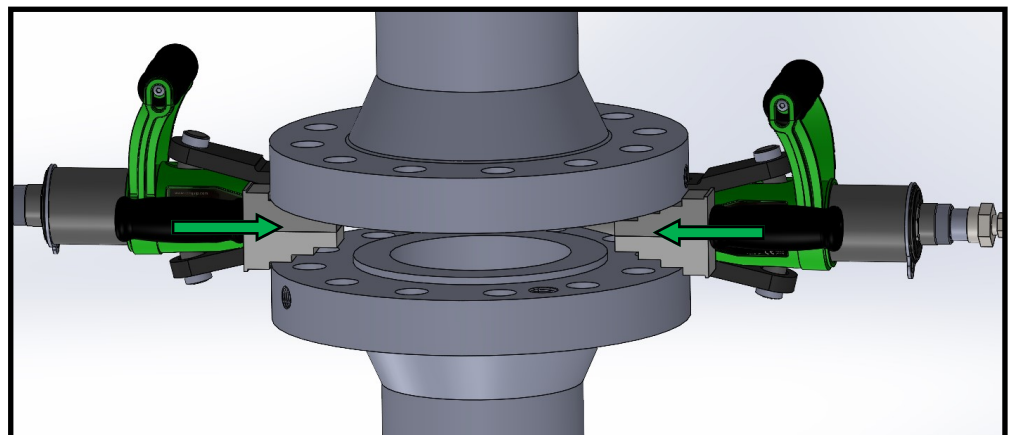

13. Reverse the spreading procedure to close the Flange Joint .

14. Ensure the system is fully de-pressurised before disconnecting couplers.

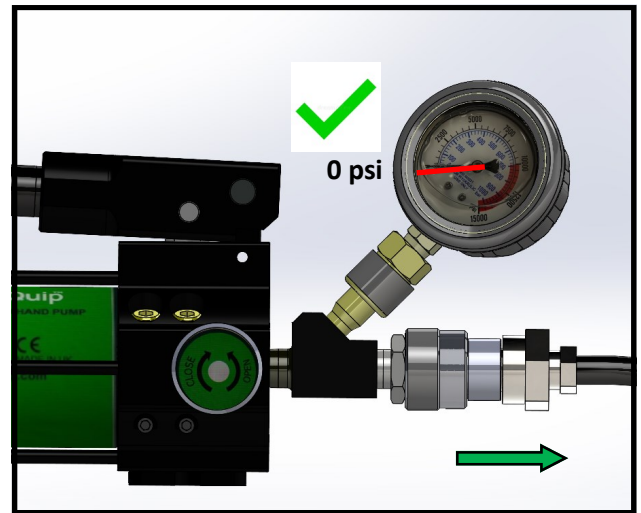

15. Clean equipment and package for storage in a cool dry location.

5.0 Stepped Block attachment and Large Safety Block

1. When required, a stepped block can be attached to the VIPER-28 to increase the spreading distance.

2. Use the retaining screw and hex key provided to attach the stepped block.

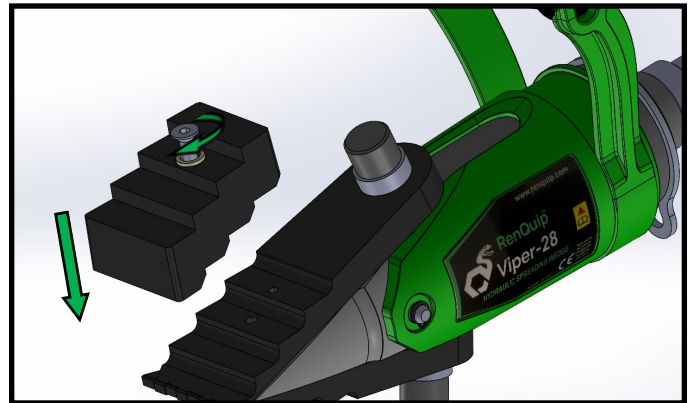

3. A second stepped block can be attached to increase the spreading distance to a maximum of **124mm (4.88")**.

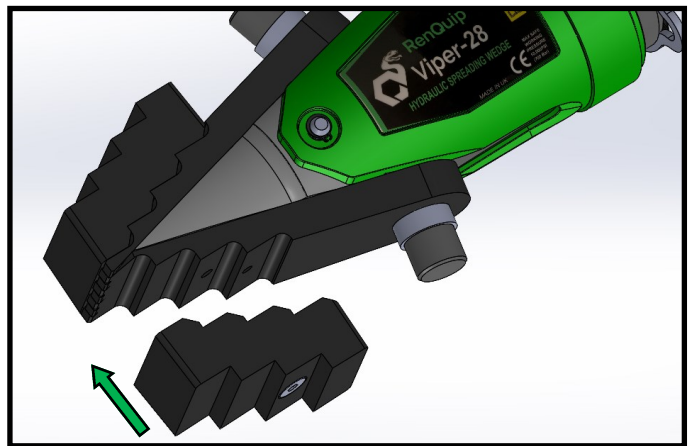

4. When the VIPER-28 is used with stepped blocks the large safety block must also be used. Unscrew and remove the top block from the small safety block.

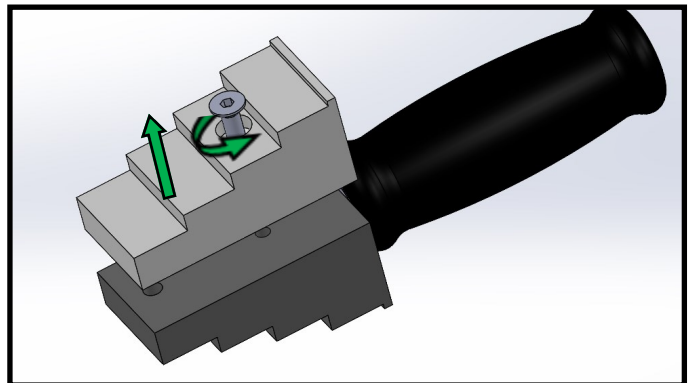

5. Fit the top block on to the large safety block and tighten the securing screw.

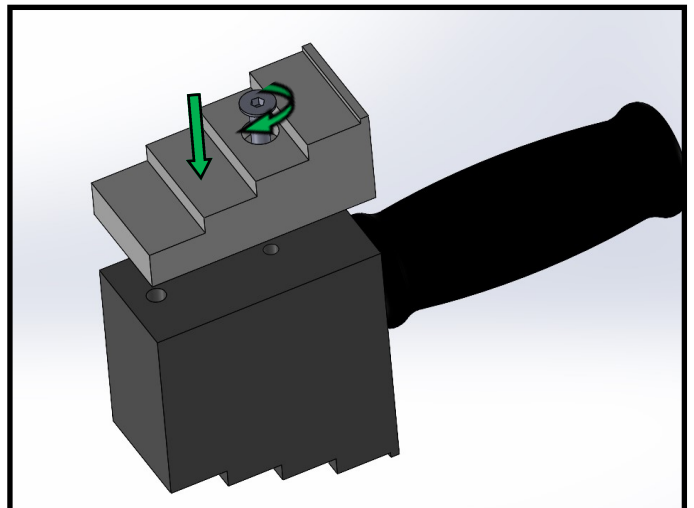

6.0 Parts List

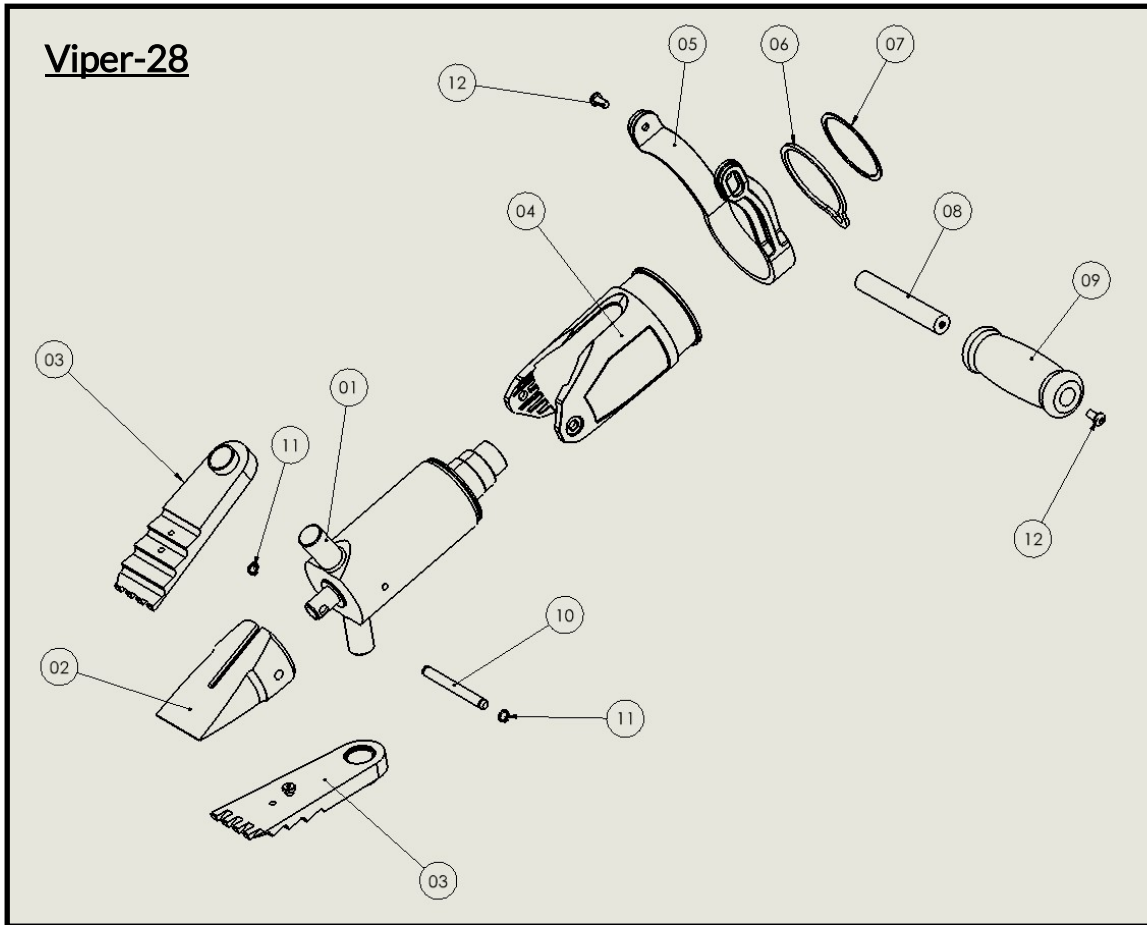

Item No	Part No	Description	Qty
01	N/A	Viper-28 Tool Body Assembly <i>(not available as a spare part)</i>	1
02	154012011	Viper-28 Driven Wedge	1
03	154013001	Viper-28 Jaw Assembly	2
04	154014001	Viper-28 Shroud Assembly	1
05	154015011	Viper-28 Handle Frame	1
06	154010011	Viper-28 Lanyard Ring	1
07	100200401	Viper-28 Spiral Ring	1
08	154015021	Viper-28 Handle Bar	1
09	100500011	Handle Grip	1
10	154012021	Viper-28 Driven Wedge Pin	1
11	100200361	Viper-28 Driven Wedge Pin Circlip	2
12	100200091	Handle Screw	2

7.0 Maintenance

- Visually Inspect the VIPER tool, jaws, wedge and coupler for any damage.
- Replace any worn or damaged parts.
- Clean and degrease surfaces and coupler.
- Ensure protective caps are fitted to cleaned couplers.
- Grease tools with a quality High load bearing grease as indicated below.

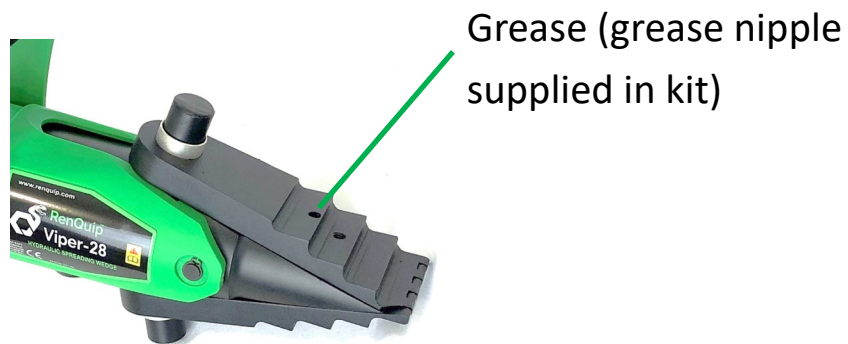

- Top up hydraulic oil in the pump as required with a high quality 32cSt hydraulic oil.
- Store tools in a cool, dry, and low humidity location.

Head Office :

RenQuip Ltd

info@renquip.com

Unit 1 Dunnottar House

Tel : +44(0) 1224001861

Howe Moss Drive

www.renquip.com

Dyce

Aberdeen

Scotland

AB21 0FN