

AT9S

Hydraulic Flange Alignment Tool only Kit

The AT9 is a Hydraulic flange alignment tool designed for medium and large flanges that is used to correct:

- **linear misalignment**
(when the axis of the two flanges are not aligned).
- **rotational misalignment**
(when the axis of the flanges are aligned but the bolt holes are not).

The AT9 can produce a maximum reaction alignment force of 90kN (9T) when the maximum hydraulic pressure of 10,000psi (700Bar) is applied to the tool.

- Tool weight 14.5Kg (32.0lbs)
- No external anchor points or rigging required.
- Can be used to prevent misalignment during flange joint maintenance.
- Bearings rated to provide overload warning.
- 100% Load/Pressure tested and certified.
- Prevents gasket pinching during flange joint assembly.
- High durability High Quality low Maintenance design.
- Supplied with pressure rated and capacity matched pump for safety.
- Robust Moulded Case for easy transportation and storage.



Engineered Energy Equipment

Product Sales | Product Rental | Bespoke Solutions

www.renquip.com

AT9S

Hydraulic Flange Alignment Tool only Kit

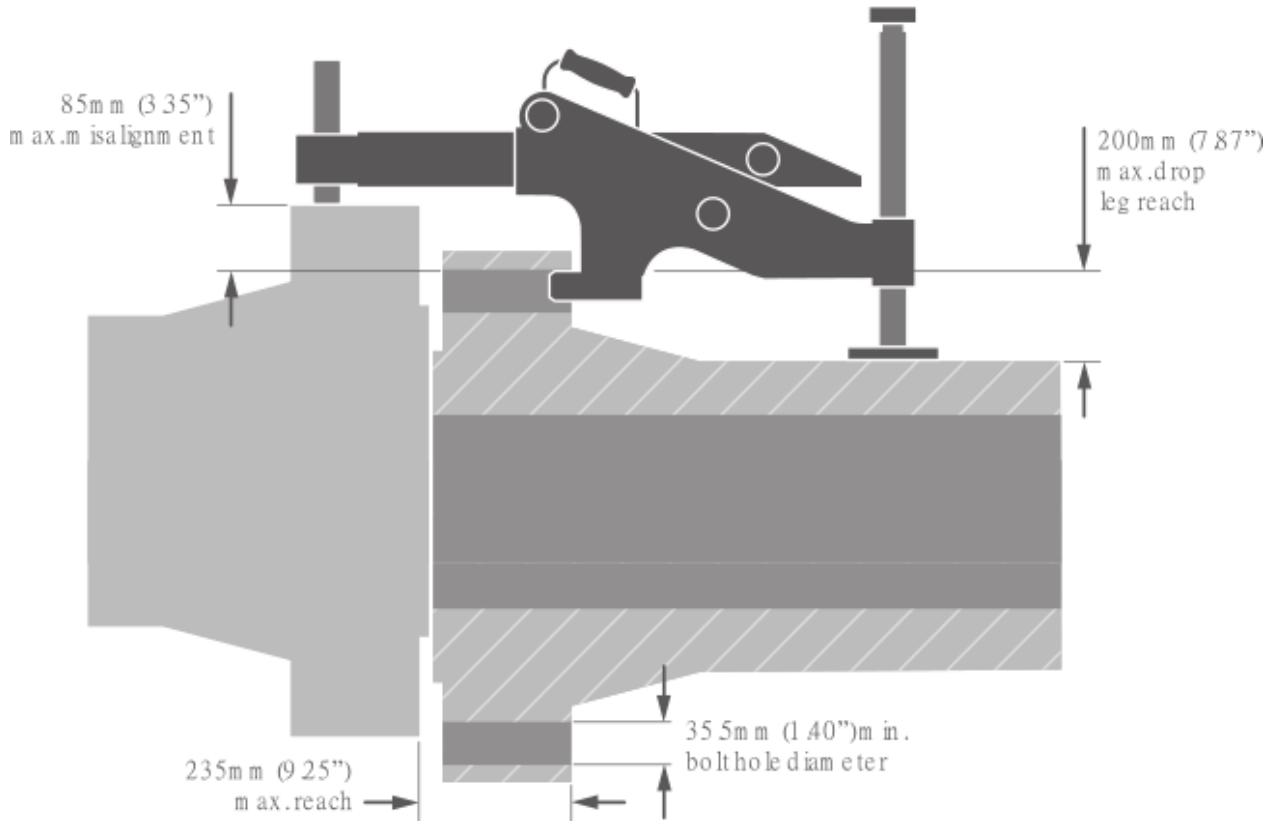

Kit Weight: 20Kg (44lbs)

Kit Dims: 920mm x 510mm x 210mm
(36.2" x 20.1" x 8.3")

Tool Weight: 14.5Kg (32lbs)

Tool Dims: 100mm x 230mm x 540mm
(3.9" x 9.1" x 21.3")

Product ordering code: AT9S

Kit Contents:

- 1 x AT9 Tool
- 1 x Ratchet and Strap
- 1 x Instruction Manual
- 1 x Robust moulded carry case



Engineered Energy Equipment

Product Sales | Product Rental | Bespoke Solutions

www.renquip.com

Unit 1 Dunnottar House, Howe Moss Drive, Dyce, Aberdeen, AB21 0FN
+44 (0) 1224001861 | info@renquip.com